

**ASSEMBLY WITH PAD**

**ASSEMBLY WITHOUT PAD**

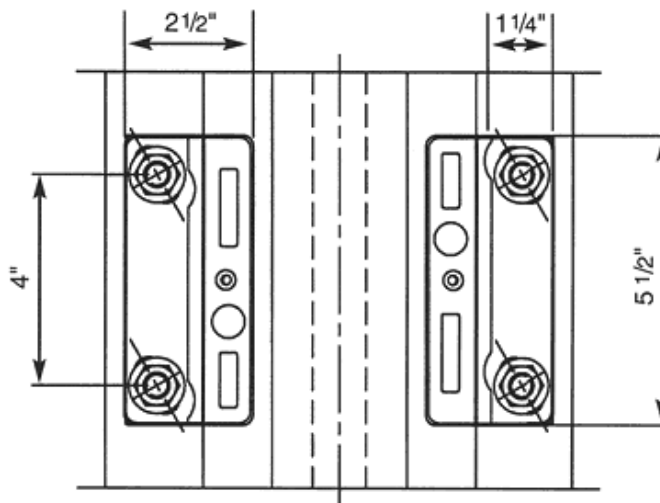
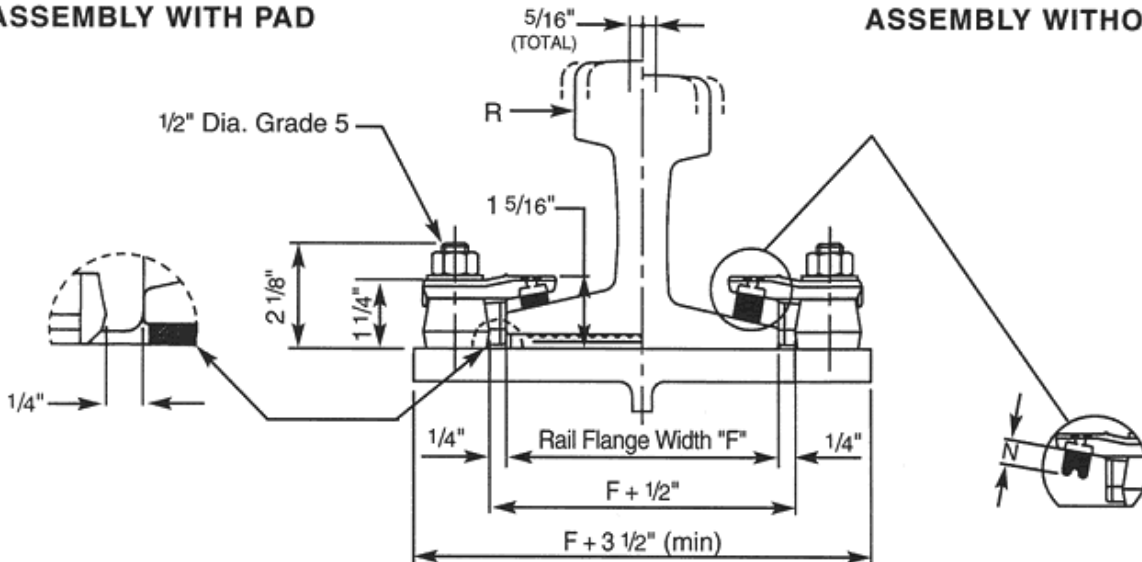

SPECIFICATIONS		COMPONENTS
• Resistance to lateral force R max.	17 kips	<b>WELDLOK 10</b>
• Bolt torque	70 ft-lbs	1 upper component No. 9212\08\33Z
• Lateral adjustment, total	5/16"	1 lower component No. 9212\--\25
• "N" available noses	3/8", 5/8", 3/4"	2 gr. 5 hex capscrews 1/2" Dia. X 1 1/2"
• Weight	3 lbs	2 gr. 5 hex nuts 1/2" Dia.
<b>NOTES</b>		2 hardened flat washers 1/2" Dia.
See "Selection Table" for "F" Dimensions.		
See "General Specifications Weldlok Series" for additional clip information.		

**GANTREX RAIL CLIP WELDLOK™ 10**

<b>SELECTION TABLE</b>					
<b>RAIL SIZE</b> (lbs/yd)	<b>F</b> (in)	<b>RAIL ONLY</b> <b>CLIP PART NO.</b>	<b>GANTREX PAD</b> <b>MODEL NO.</b>	<b>RAIL ON GANTREX PAD</b> <b>CLIP PART NO.</b>	<b>AT SPLICE BAR</b> <b>CLIP PART NO.</b>
40 ASCE	3 1/2"	N/A	85 RFS	WELDLOK 10/40PZ	WELDLOK 10CZ (4 per joint)
60 ASCE	4 1/4"	WELDLOK 10/60Z	105 RFS	WELDLOK 10/60PZ	
85 ASCE	5 3/16"	WELDLOK 10/85Z	130 RFS	WELDLOK 10/85PZ	
104 CR	5"	WELDLOK 10/104Z	130 RFS	CONSULT GANTREX	
105 CR	5 3/16"	WELDLOK 10/105Z	130 RFS	CONSULT GANTREX	
135 CR	5 3/16"	WELDLOK 10/135Z	130 RFS	CONSULT GANTREX	

**NOTES**

- 1) To order clips without rubber noses consult GANTREX for proper selection.
- 2) GANTREX clips are available to suit most rail sections. Please consult GANTREX for details if your rail does not appear in the above table.
- 3) GANTREX recommends that rail joints be welded wherever possible.
- 4) Ask GANTREX for information on **extra low profile** clips.
- 5) Contact GANTREX for available protective coatings.

**MATERIALS**

Upper Component . . . . . Ductile Cast Iron  
 Lower Component . . . . . Weldable Forged Steel  
 Pressure Block (Nose) . . . . . Synthetic Rubber

**INSTALLATION**

The lower component is welded to the support parallel to the axis of the rail and the upper component fastened to it by means of two 1/2" Dia. Grade 5 hex head capscrews. For full instructions, refer to GANTREX Weldlok 10 Series Suggested Weld and Installation Instruction sheet. Do not use cleaning fluids or protective coatings which contain ketones or similar chemicals, as they may seriously damage the rubber nose.

For complete crane runway installation services including rail welding, please contact GANTREX SYSTEMS through any of the sales offices listed below.

GANTREX reserves the right to discontinue or change specifications at any time without prior notice and without incurring any obligation whatsoever.



**TOLL FREE: 800 2 GANTREX (800) 242-6873**

**Web site: [www.gantrex.com](http://www.gantrex.com) • Email: [sales@gantrex.com](mailto:sales@gantrex.com)**

© GANTREX, 2008  
 PRINTED in U.S.A.

Rev. 9/09