

**PERFORMANCE CHARACTERISTICS:**

**STROKE** (15 3/4 ins) 400 mm  
**ENERGY CAPACITY** (175,500 ft lbs) 238 kJ

**STATIC RESISTANCE:**

The graphs below show the static resistance at a **slow closure speed**, not at impact speed. Consult Gantrex if a reduced static resistance is required.

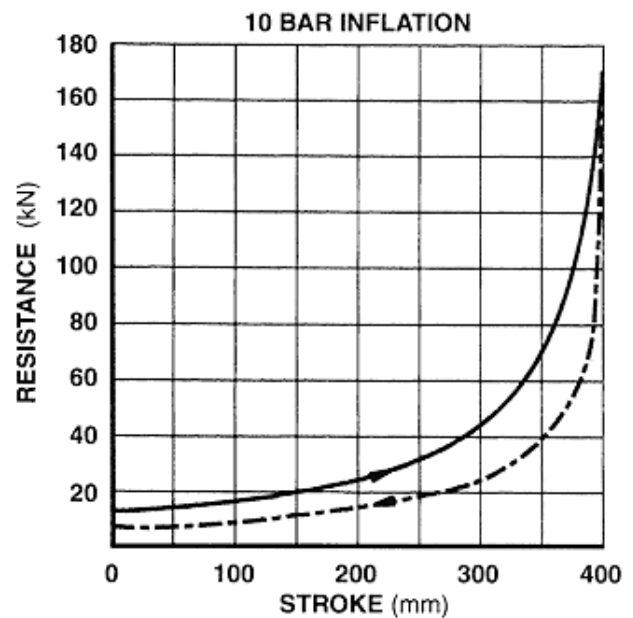
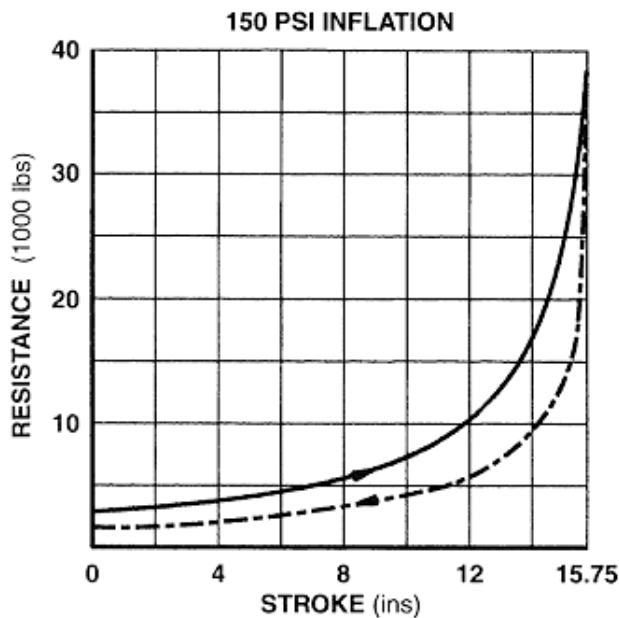

**METERING PIN SELECTION:**

USE "We" AS DETERMINED IN BUMPER SELECTION CALCULATIONS

IMPACT WEIGHT (We)		Metric Tonnes	METERING PIN CODE*
(1000 lbs)			
UP TO	22	10	04
" "	44	20	05
" "	88	40	07
" "	176	80	08
" "	330	150	10
" "	662	300	12
" "	1323	600	15
" "	1764	800	17
" "	2205	1000	19
" "	4410	2000	22

**MOUNTING BRACKET SELECTION:**

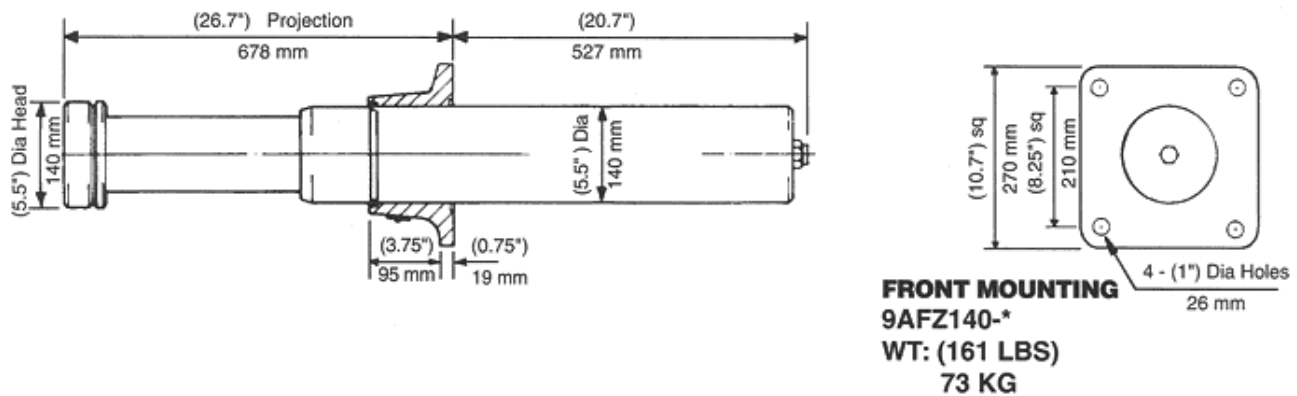
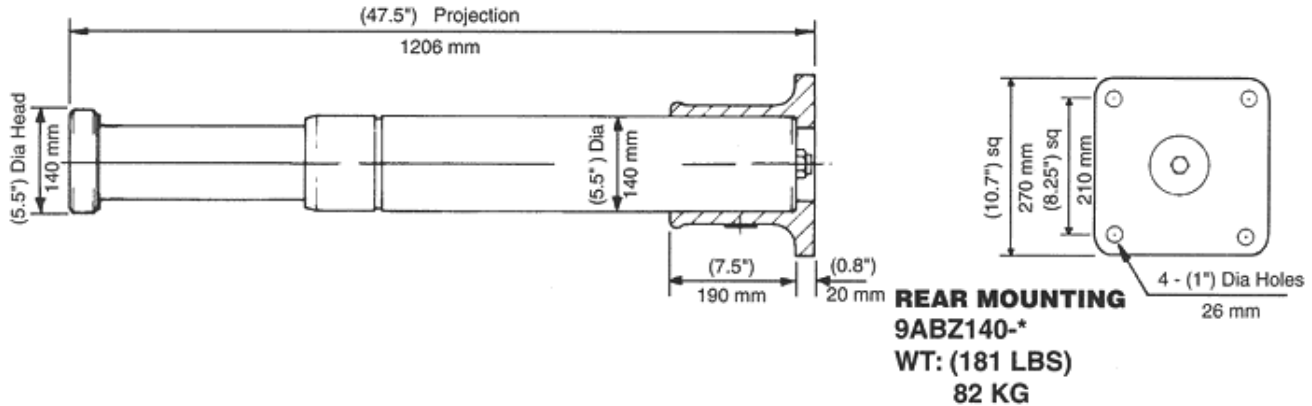

\* Indicates Metering Pin Code (See over - Metering Pin Selection Table)

- EXTERNAL FINISH:** PLUNGER IS MARINE PLATED. ALL OTHER SURFACES HAVE RED OXIDE PRIMER READY FOR FINISH COAT OF PAINT.
- SAFETY CABLE:** REQUIRED TO MEET AIST AND OSHA CODES. SPECIFY BY REPLACING FIRST LETTER "A" IN MODEL CODE WITH "S" E.G. 9SFZ140-12.
- PROTECTIVE BELLOWS:** SPECIFY USING SUFFIX "B" E.G. 9AFZ140-12B.
- HIGH TEMPERATURE SEALS:** USE WHERE AMBIENT TEMPERATURE IS HIGHER THAN 140°F. SPECIFY USING SUFFIX "H" E.G. 9AFZ140-12H.
- LOW DRIVE DOWN FORCE:** REDUCED PRE-CHARGED PRESSURE TO ALLOW FULL COMPRESSION UNDER DRIVE MOTORS. CONSULT GANTREX FOR ASSISTANCE. SPECIFY USING SUFFIX "L" E.G. 9AFZ140-12L.
- MOUNTING BRACKETS:** AVAILABLE IN STANDARD, LOW AND VERY LOW FOOT MOUNTING BRACKETS. CRANE STOPS AND EXTENDER BRACKETS ARE ALSO AVAILABLE. CONSULT GANTREX FOR PROPOSAL DRAWING.